

## Instrucciones de montaje

Lea atentamente estas instrucciones y advertencias antes de instalar el producto y conserve este documento para futuras consultas, con el fin de garantizar un uso seguro y prolongar su vida útil.

- Producto diseñado exclusivamente para uso doméstico, no apto para saunas ni baños de vapor.
- Se recomienda una instalación por dos personas cualificadas y conforme a la normativa aplicable.
- Diseñado para instalarse en paredes de ladrillo o mampostería. En otras superficies, utilice fijaciones adecuadas y asegure una capacidad de carga suficiente.
- Utilice protección ocular durante la perforación.
- Extrema las precauciones al usar herramientas eléctricas cerca del agua; se recomienda un dispositivo de corriente residual (RCD).
- Compruebe la existencia de cables o tuberías antes de perforar. En superficies alicatadas, evite el deslizamiento del taladro.
- No exceda la carga de los estantes o la unidad.
- No se siente, suba ni permanezca de pie sobre la unidad.
- Elimine el agua acumulada o la humedad superficial para evitar daños y conservar el producto en buen estado.



Destornillador  
Screwdriver



Lápiz  
Pencil



Metro  
Tape measure



Nivel  
Spirit level

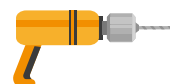

Taladro  
Drill



Pistola  
Speed clamps



Broca  
Suitable drill bit

## Fitting instructions

Please read the instructions and warning carefully before installing the product and ensure this document is kept for future reference to ensure longevity of the product.

- This product is intended for domestic use only, not for use in high humidity spaces such as saunas or steam rooms.
- Installation by two suitably qualified persons, in accordance with the applicable regulations, is recommended.
- This product is designed for installation on brick or masonry block walls. If mounting onto other material, ensure appropriate fixing and ensure sufficient load-bearing capacity.
- When drilling use appropriate eye protection.
- Take extreme care when using power tools near water – the use of a residual current device (RCD) is advised.
- Beware of hidden cables or pipes. Take care if drilling on tiled surfaces, to prevent the drill from slipping.
- Do not overload shelves or unit.
- Do not sit, climb or stand on the unit.
- Remove any accumulated water or surface moisture to prevent damage and keep the product in good condition.

## ■ ■ Instructions de montage

**Lisez attentivement ces instructions et avertissements avant l'installation. Conservez ce document pour toute consultation ultérieure.**

- Produit conçu exclusivement pour un usage domestique.
- Ne convient pas aux saunas ni aux hammams.
- Il est recommandé que l'installation soit effectuée par deux personnes qualifiées, conformément aux réglementations applicables.
- Produit conçu pour une installation sur des murs en briques ou en maçonnerie. Pour tout autre type de surface, utilisez des fixations adaptées et assurez-vous que la capacité de charge du mur est suffisante.
- Utilisez une protection oculaire appropriée lors du perçage.
- Faites preuve de prudence lors de l'utilisation d'outils électriques à proximité de l'eau ; l'utilisation d'un dispositif différentiel résiduel (DDR) est recommandée.
- Vérifiez l'absence de câbles ou de canalisations dissimulés avant de percer. Sur des surfaces carrelées, veillez à éviter tout glissement de la perceuse.
- Ne dépassez pas la charge maximale des étagères ou du meuble.
- Ne vous asseyez pas, ne montez pas et ne vous tenez pas debout sur le meuble.
- Éliminez toute accumulation d'eau ou humidité de surface afin d'éviter les dommages et de préserver le produit en bon état.



Tournevis  
Cacciavite



Crayon  
Matita



Mètre  
Metro



Niveau  
Livella

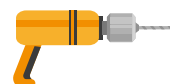

Perceuse  
Trapano



Pistolet  
Pistola per  
silicone



Mèche  
Punta per  
trapano

## ■ ■ Fitting instructions

**Leggere attentamente queste istruzioni e avvertenze prima di installare il prodotto e conservare questo documento per future consultazioni, al fine di garantire un uso sicuro e prolungarne la vita utile.**

- Prodotto progettato esclusivamente per uso domestico, non adatto per saune o bagni di vapore.
- Si consiglia un'installazione eseguita da due persone con le qualifiche necessarie e in conformità con le normative applicabili.
- Progettato per essere installato su pareti in mattoni o muratura. Per altre superfici, utilizzare fissaggi adeguati e garantire una capacità di carico sufficiente.
- Utilizzare una protezione per gli occhi durante la perforazione.
- Prestare la massima attenzione quando si utilizzano utensili elettrici vicino all'acqua; si consiglia un interruttore differenziale (RCD).
- Verificare la presenza di cavi o tubi nascosti prima di forare. Sulle superfici piastrellate, evitare lo slittamento del trapano.
- Non superare il carico massimo dei ripiani o dell'unità.
- Non sedersi, salire o rimanere in piedi sull'unità.
- Rimuovere l'acqua accumulata o l'umidità superficiale per evitare danni e conservare il prodotto in buone condizioni.

**1. Montar los costados exteriores / Assemble the outer sides /  
Monter les côtes extérieures / Montare i fianchi esterni**

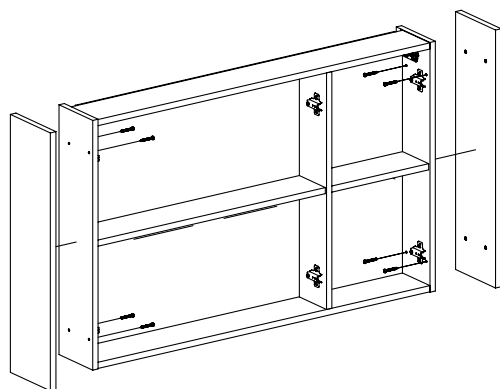

**2. Posicionar y colgar camerino / Position and hang the mirror cabinet /  
Placer et suspendre le armoire miroir / Posizionare e appendere**

2.1 Posicionar el camerino a la altura deseada / Position the mirror cabinet at desired height / Placer le armoire miroir à l'hauteur souhaitée / Posizionare lo specchio contenitore all'altezza desiderata

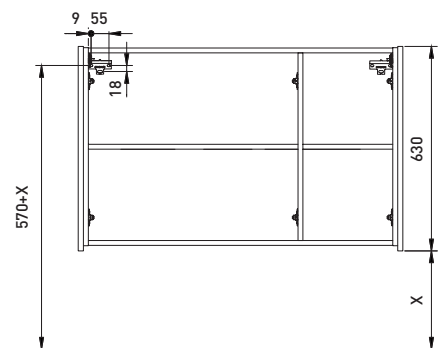

2.2 Atornillar placa y colgar Camerino / Screw the plate and hang the mirror cabinet / Visser la plaque et accrocher le armoire miroir / Avvitare la piastra e appendere lo specchio contenitore

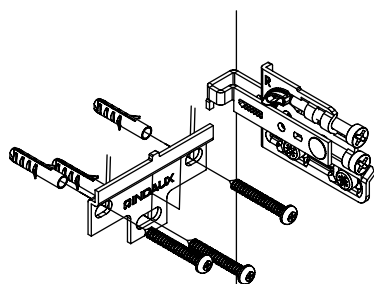

2.3 Regular camerino y colocar embellecedor / Adjust and put the embellisher / Réguler le armoire miroir et placer les enjoliveurs / Regolare lo specchio contenitore e inserire il copriforo

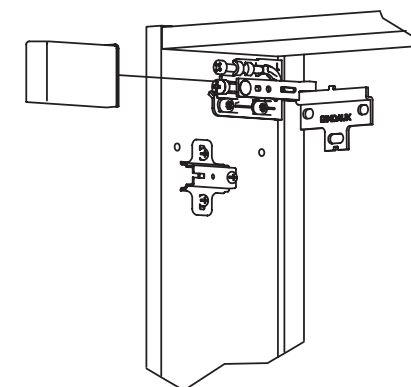
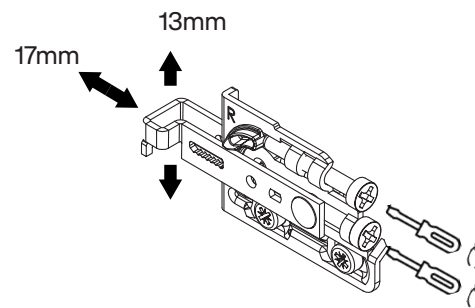

3. Regulación de puertas / Adjust doors / Réguler les portes / Regolazione delle ante

